



GemX™ IntelliFresh® Coffee Brewer with FreshTrac® Dispenser

Model: G4GEMXSIFTR10A3026*



■ Features

Reduce labor while increasing capacity – Up to 300% more capacity.

Reduce waste – Supports smaller batch sizes for slower dayparts.

Save valuable counter space – Narrow footprint uses 11% less width and 13% less depth.

* Dispenser sold separately.
Single and twin warming stands sold separately.

Additional Features

Mobile coffee dispensers. Add/remove dispensers and warmers anytime and anywhere.

Increase cup quality and consistency. Restriction Brew technology prevents brewing if old coffee is detected in the dispenser. GemX ensures each dispenser is pre-heated prior to brewing, so every cup is served at the ideal temperature.

Next generation coffee dispensers. Modern design with large, color changing LED lights representing coffee freshness and volume. Keeps coffee fresh and hot for one hour, twice as long as glass carafe brewers.

Plastic brew cone. Plastic maintains a consistent temperature during brewing unlike metal alternatives that quickly lose temperature resulting in inconsistent coffee flavor.

Automatic brew cone lock. Brew cone automatically locks into place during brewing process, preventing users from accidentally removing it.

Quick and easy updates. Software and recipe updates take less than 30 seconds through the USB port.

Minimize down time. The self-diagnostic system runs tests on critical components to troubleshoot and ensure service providers arrive with the right parts, minimizing down time. GemX also issues on screen warnings when water scale or pressure impact brewing.

Best in class warranty. GemX is backed by a 3-year parts and labor warranty on the digital control board and touch screen. All other components are supported with a 2-year parts and labor warranty. See warranty statement for full details.

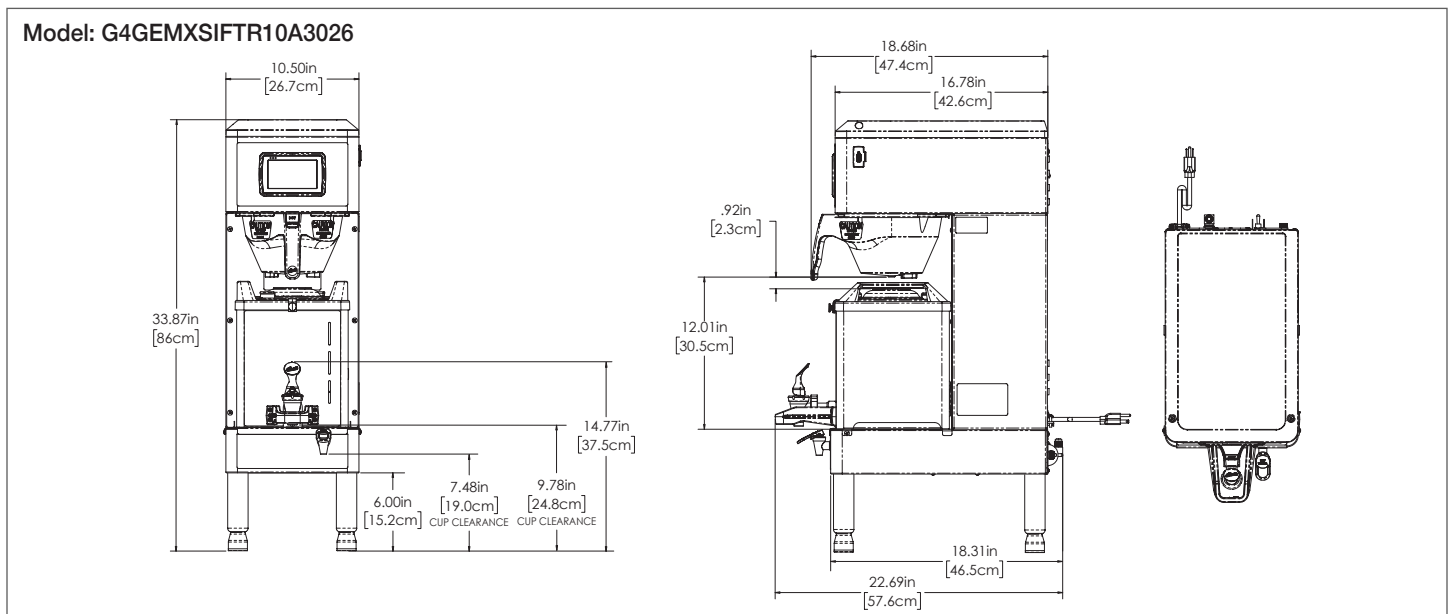

Dimensions

MODEL#	DESCRIPTION	HEIGHT x WIDTH x DEPTH	SHIP WEIGHT	SHIP CUBE
G4GEMXSIFTR10A3026	Single, 1.5 Gallon with IntelliFresh, FreshTrac and Dispenser Detect	33.87" x 10.50" x 22.69"	51.0 lbs.	7.00 cu. ft.

Utility Requirements

MODEL#	ELECTRICAL							WATER			
	PHASE	VOLTS	AMPS	WIRE	WATTS	HERTZ	PLUG	CONNECTOR	PRESSURE	MINIMUM FLOW RATE	TANK VOL.
G4GEMXSIFTR10A3026	1 PH	220V	18.5A	3W+G	4050W	50/60Hz	L14-20P	1/4" Quick-Connect Flare	20 - 90 psi	1.0 GPM	2.2 gal

Accessories



GEM3XRBA026
1.5 Gallon Dispenser
with FreshTrac



GEM5XSIFT10A026
Single Warmer Stand



GEM5XTIFT10A026
Twin Warmer Stand



WC-3417
Brew Basket with
Hot Coffee Splash Pocket



WC-29050
Amber AFS Sprayhead



WC-32005ORG
Decaf Handle



GEM-6
Coffee Filter 12-1/2" x 4"



DT-8
8" Stainless Steel Drip Tray

* Accessories sold separately.



WARNING - These products can expose you to chemicals including Acrylamide and Bisphenol A (BPA), which are known to the State of California to cause cancer and birth defects or other reproductive harm. For more information visit www.P65Warnings.ca.gov

