



# GemX™ Narrow IntelliFresh® Coffee Brewer with Narrow FreshTrac® Dispenser

Model: G4GEMXNR10A3026



## ■ Features

- **Save valuable counter space.** Store two 1.5 Gallon dispensers in the space of a standard GemX.
- **Freshness indicator.** Modern design with large, color changing LED lights representing coffee freshness and volume. Keeps coffee fresh and hot for one hour.
- **Reduce waste.** Supports smaller batch sizes for non-peak hours.

## Additional Features

- **Mobile coffee dispensers.** Add/remove dispensers and warmers, anytime and anywhere.
- **Increase cup quality and consistency.** Restriction Brew technology prevents brewing if old coffee is detected in the dispenser. GemX Narrow ensures each dispenser is pre-heated prior to brewing, so every cup is served at the ideal temperature.
- **Rotating brew basket.** No need to move dispensers for brewing.
- **Automatic brew cone lock.** Brew cone automatically locks into place during brewing process, preventing users from accidentally removing it.
- **Quick and easy updates.** Software and recipe updates take less than 30 seconds through the USB port.
- **Minimize down time.** The self-diagnostic system runs tests on critical components to troubleshoot and ensure service providers arrive with the right parts, minimizing down time. GemX Narrow also issues on screen warnings when water scale or pressure impact brewing.
- **Best in class warranty.** GemX Narrow is backed by a 3-year parts and labor warranty on the digital control board and touch screen. All other components are supported with a 2-year parts and labor warranty. See warranty statement for full details.

Model: G4GEMXNR10A3026

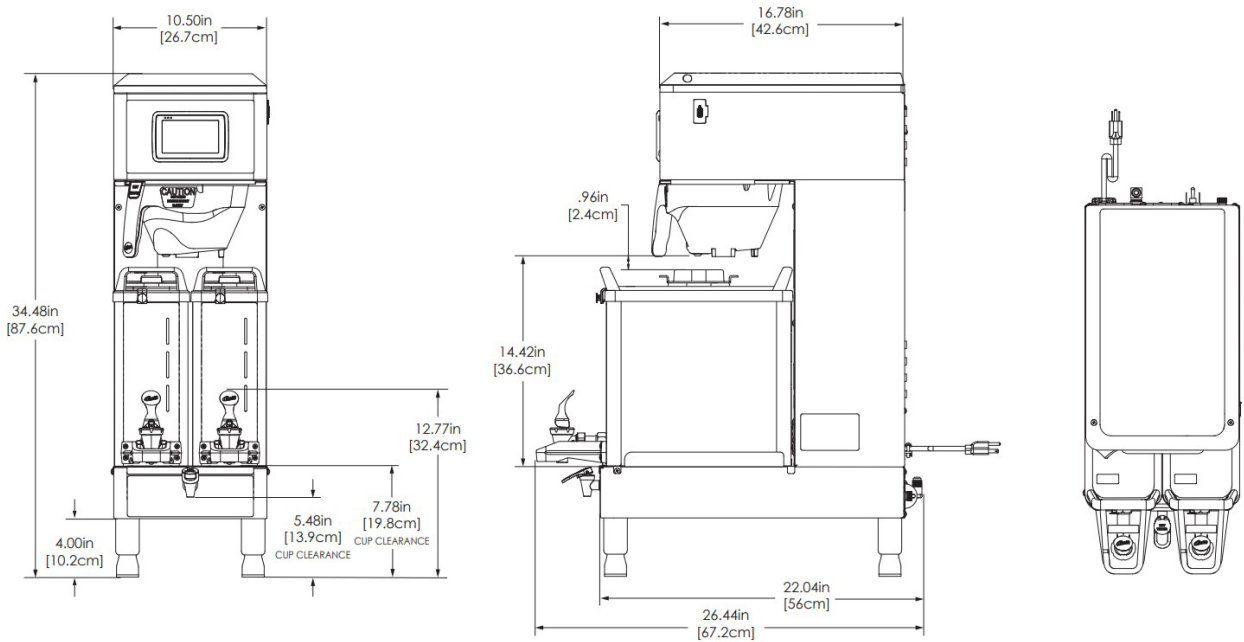

### Dimensions

MODEL#	DESCRIPTION	HEIGHT x WIDTH x DEPTH	SHIP WEIGHT	SHIP CUBE
G4GEMXNR10A3026	G4 GemX Gemini® IntelliFresh® 1.5 Gal Coffee Brewer, FreshTrac and Dispenser Detect	34.48"H x 10.50"W x 26.44"D	75.0 lbs.	9.60 cu. ft.

### Utility Requirements

MODEL#	ELECTRICAL							WATER			
	PHASE	VOLTS	AMPS	WIRE	WATTS	HERTZ	PLUG	CONNECTOR	PRESSURE	MINIMUM FLOW RATE	TANK VOL.
G4GEMXNR10A3026	1 PH	220V	18.5A	3W+G	4050W	50/60Hz	L14-20P	1/4" Quick Connect Flare	20 - 90 psi	1.0 GPM	2.2 gal

### Accessories



GEM3XNRBA026  
1.5 Gallon Dispenser  
with FreshTrac



GEM5XNS10326  
Single Warmer Stand



GEM5XN10A326  
Twin Warmer Stand



WC-3424-101  
Brew Basket with  
Hot Coffee Splash Pocket



WC-29050  
Amber AFS Sprayhead



WC-32005ORG  
Decaf Handle



GEM-6  
Coffee Filter 12-1/2" x 4"



DT-8  
8" Stainless Steel Drip Tray

\* Accessories sold separately.

**WARNING** - These products can expose you to chemicals including Acrylamide and Bisphenol A (BPA), which are known to the State of California to cause cancer and birth defects or other reproductive harm. For more information visit [www.P65Warnings.ca.gov](http://www.P65Warnings.ca.gov)

